

TVAN FIRETAIL



**From
\$88,800**

MK6

Travel Height: 2250mm
Travel Width: 1920mm
Travel Length: 4900mm
Setup length: 6600mm

Ball Weight: 170kg*
Tare: 1100kg*
ATM: 1800kg

Australian made steel
Australian made canvas
5 year chassis warranty
5 year suspension warranty

The new **MK6 Tvan Firetail** builds on over 26 years of Tvan legacy offering familiar inclusions and options but now also with:

- Increased headroom over the bed
- Increased front boot capacity
- Increased pantry capacity
- Increased glass window size option
- Increase quick awning size
- Updated lighting, aesthetic and structural improvements



TRACK.
"RVs THAT INSPIRE"

Power

2 x 125Ah lithium batteries (200Ah usable)
Redarc 2000W pure sine wave inverter
Roof mounted 200W solar panel
Redarc Manager Alpha 50 with RedVision Display
3 x USB outlets on RHS & LHS of bed
2 x 240V kitchen outlets (dual supply power provided by inverter)
Merit, accessory and USB sockets throughout

Water

108L water tank (rear mounted)
Draw water from an external source (jerry can or bucket)

Premium Kitchen

Stainless steel slide out external kitchen
3 burner gas cooktop with Piezo ignition
Hot and cold water plumbed to kitchen
Under kitchen LED light
Yellow and white light over kitchen
1 x 12V merit plug in kitchen locker

Interior Refinements

Roof storage system
Side wall storage pockets
Under mattress liner
3-speed fan with timer
Diesel hot water and heating (incl ensuite tent)
Hatch-mounted entry light (above tent door)
2 x roof hatches with blinds and midge screens
Genuine Australian made canvas (Dynaproofed)
Magnetised tent fittings and window curtains
LED light in tent
4 x LED lights individually switched
2 x reading lights individually switched
Insulated wall panels and fabric lined roof

Outdoor Living (Note: all canvas is Jet Grey)

Quick Cover™ swing out awning

Suspension, Chassis, Body & Wheels

Military grade MC2 suspension®
1.8 tonne suspension
Hot dipped galvanised chassis
Bump stops to suit 33" diameter tyres
17 x 8 Alloy wheels
Off-road 12" electric brakes and hand brake
Side pannier for 20L jerry can
LED tail lights and side clearance markers
Rear wood rack
Easylift heavy duty jockey wheel
Flat 7 pin trailer plug

Drawbar

DO35 3.5 tonne fully articulated off-road coupling
Aluminium checker plate step and spirit level
2 x 4kg gas bottles
Stone deflectors
Spare wheel mount

Storage (Note: LHS is kitchen side of Tvan)

2 x sealed and vented lockers
Anderson plug in LHS locker plus slide with tie-down points for fridge (up to 95L)
Slide out staging table under fridge slide
Adjustable shelf in RHS locker
Single handed operation of slide lock bars
Storage locker lighting

General Specifications

Overall length in travel mode	4900mm
Overall width	1920mm
Interior setup length	4800mm
Overall length in setup mode	6600mm
Height with Quick Awning (unladen)	2250mm
Tent area size (on the deck)	1700mm x 2100mm
Wheel track	1650mm
Departure angle	30 degrees
Suspension travel	250mm
ATM	1800kg
Water tank	108L
Jerry cans	Up to 4



All model specifications and pricing details are subject to change.
 *Tare and Ball Weights are a guide only and may change depending on Tvan model, drawbar layout and options fitted to your camper.
 Dealer delivery fees may apply.

TRACK
 "RVs THAT INSPIRE"

Power	RRP (inc GST)
2 x 250Ah lithium batteries (400Ah usable)	\$5,796
2 x 375Ah lithium batteries (600Ah usable)	\$7,996
Credit when replacing 2 x 125Ah lithium batteries	-\$3,500
Redarc 160W monocrystalline solar blanket (rear hatch mounted)	\$850
Redarc Manager Alpha75 with RedVision Display	\$4,899
Redarc Manager Alpha100 with RedVision Display	\$5,899
Credit when replacing Redarc Manager Alpha50	-\$3,999

Water	RRP (inc GST)
Additional 70L water tank	\$1,510

Interior Refinements	RRP (inc GST)
Additional 3-speed fan with timer	\$340
Fabric lined headboard	\$285
Skyward™ rear lift deck for easy access	\$3,200
Bed tie-down rails (pair)	\$190
Sliding glass windows with midge-proof mesh	\$3,050
Ultimate pocket spring mattress upgrade	\$715

Suspension, Chassis, Body and Wheels	RRP (inc GST)
Customise suspension to best suit tow vehicle specifications (conditions apply)	POA
Underbody protection mudflaps	\$410
Ark dual wheel height adjustable solid jockey wheel	\$350

Trim Colour Options (Eucalypt is standard)	RRP (inc GST)
Trim colour options	POA

Outdoor Living (Note: all canvas is Jet Grey)	RRP (inc GST)
Rear insect screen (midge proof mesh)	\$399
Rear insect canvas screen	\$699
2 x additional tent windows and vent under bed	\$765
Tropical roof (in lieu of catch net)	\$990
Zip on family room tent with solid vinyl floor	\$1,699
Triangular sail awning	\$399
Quick Cover™ shade wall kit (2 x walls)	\$799
Annex – roof, kitchen end and fridge wall	\$2,170
Annex – 2 nd end wall with or without window	\$599
Annex – long (side) wall with 2 x windows and door	\$1,499
Draught skirt	\$479
Additional plumbed gas line with quick snap connector (for use with “flame failure” gas device)	\$255

Storage	RRP (inc GST)
Front boot pantry LHS	\$1,220
Evakool 95L RF fridge/freezer with MSA tiedown straps	\$2,100
Additional adjustable shelf in RHS front boot	\$250
Anderson plug in RHS front boot	\$65
Storage slide out tray and tie-down points on RHS	\$620
Drawbar extension	\$750
ISI 2 bike rack inc chassis mount (requires drawbar extension)	\$1,475
ISI 4 bike rack inc chassis mount (requires drawbar extension and spare wheel relocation)	\$1,849
Underbody spare wheel relocation	\$499
Optional ISI car fit kit (vehicle info required for specific pricing)	POA
Under bed sheet metal drawer storage system	\$730
Maxtrax mounting pins	\$150



The **MK6 generation** builds on the rock-solid reputation Tvan's have established over 26 years. They are known for their bulletproof build and go-anywhere off-roadability since they first hit the market.

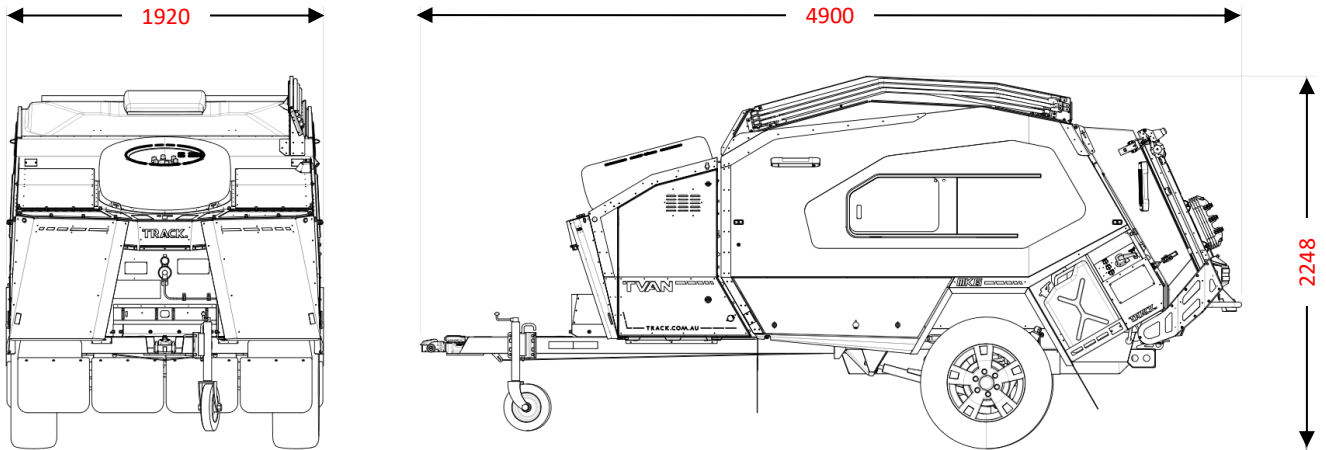

For the first time since the Tvan's introduction, the side body profile undergoes a substantial redesign in the MK6. This change allows for **greater headroom, improved practicality, and a more spacious feel**, particularly toward the front of the van.

The shape of the side windows, one of the Tvan's most distinctive visual features, has also changed to suit the new body shape. Noticeably **20% larger glass opening windows** will let **significantly more light** into the interior, enhancing the feeling of spaciousness. **Improved interior lighting** will further contribute to a **brighter and more modern feel**.

The Quick Cover™ awning has been redesigned to offer significantly **more coverage and increased headroom**, particularly at the front of the van.

The new front boot for the Tvan MK6 receives a substantial refresh with **new options and features** including:

- a **40% larger fridge compartment** and
- a **20% larger pantry**.

The rear deck receives **aesthetic and structural improvements**.



TRACK is proudly represented by your local dealer:



www.tracktrailer.com.au
 sales@tracktrailer.com.au
 Tel: 03 8727 6100



RVMAP™



MC2 ASYMMETRIC LINK SUSPENSION

TRACK.
 "RVs THAT INSPIRE"