

# TVAN MURRANJI



**From  
\$98,900**

# MK6

Travel Height: 2250mm  
Travel Width: 1920mm  
Travel Length: 4900mm  
Setup length: 6600mm

Ball Weight: 170kg\*  
Tare: 1250kg\*  
ATM: 1800kg

Australian made steel  
Australian made canvas  
5 year chassis warranty  
5 year suspension warranty

The new **MK6 Tvan Murrnji** builds on over 26 years of Tvan legacy offering familiar inclusions and options but now also with:

- Increased headroom over the bed
- Increased front boot capacity
- Increased pantry capacity
- Increased glass window size
- Increase quick awning size
- Updated lighting, aesthetic and structural improvements



**TRACK.**  
"RVs THAT INSPIRE"

# TVAN MURRANJI **MKE** *standard inclusions*

## Power

2 x 125Ah lithium batteries (200Ah usable)
350W pure sine wave inverter
Roof mounted 200W solar panel
Redarc Manager 30 with RedVision Display
3 x USB outlets on RHS & LHS of bed
2 x 240V kitchen outlets
Merit, accessory and USB sockets throughout

## Water

108L water tank (rear mounted)
Additional 70L water tank (front mounted)
Draw water from an external source (jerry can or bucket)

## Interior Refinements

Roof storage system
Side wall storage pockets
Under mattress liner
2 x 3-speed fans with timer
Diesel hot water and heating (incl ensuite tent)
Hatch-mounted entry light (above tent door)
2 x roof hatches with blinds and midge screens
Genuine Australian made canvas (Dynaproofed)
Sliding glass windows with midge-proof mesh and window curtains
Hatch mounted entry light above door and LED light in tent
4 x LED lights individually switched
2 x reading lights individually switched
Insulated wall panels, fabric lined roof and headboard
Ultimate pocket spring mattress
Bed tie-down rails

## Outdoor Living (Note: all canvas is Jet Grey)

Quick Cover™ swing out awning
Skyward™ rear lift-up deck for easy access
2 additional tent windows and vent under bed
Rear insect screen midge-proof mesh

## Suspension, Chassis, Body & Wheels

Military grade MC2 suspension®
1.8 tonne suspension incl. 12" off-road electric drum brakes and handbrake
Hot dipped galvanised chassis
Bump stops to suit 33" diameter tyres
17 x 8 Alloy wheels
Side pannier for 20L jerry can
LED tail lights and side clearance markers
Underbody protection mudflaps
ARK dual wheel height adjustable jockey wheel
Flat 7 pin trailer plug

## Drawbar

DO35 3.5 tonne fully articulated off-road coupling
Aluminium checker plate step and spirit level
2 x 4kg gas bottles
Stone deflectors
Spare wheel mount

## Storage (Note: LHS is kitchen side of Tvan)

2 x sealed lockers with slide out trays and tie-down points and Anderson plug in LHS locker
Slide out staging table under fridge slide
Pantry above fridge on LHS
Evakool 95L dual zone fridge / freezer with MSA tiedown straps
Single handed operation of slide lock bars
Adjustable shelf in RHS locker
Storage locker lighting
Under-bed sheet metal drawer storage system
Maxtrax mounting pins

## Premium Kitchen

Stainless steel slide out external kitchen
3 burner gas cooktop with Piezo ignition
Hot and cold water plumbed to kitchen
Under kitchen LED light
Yellow and white light over kitchen
1 x 12V merit plug in kitchen locker

## General Specifications

Overall length in travel mode	4900mm
Overall width	1920mm
Interior setup length	4800mm
Overall length in setup mode	6600mm
Height with Quick Awning (unladen)	2250mm
Tent area size (on the deck)	1700mm x 2100mm
Wheel track	1650mm
Departure angle	30 degrees
Suspension travel	250mm
ATM	1800kg
Water tank	108L
Jerry cans	Up to 4



All model specifications and pricing details are subject to change.  
 \*Tare and Ball Weights are a guide only and may change depending on Tvan model, drawbar layout and options fitted to your camper.  
 Dealer delivery fees may apply.

**TRACK**  
 "RVs THAT INSPIRE"

Suspension, Chassis, Body and Wheels	RRP (inc GST)
Customise suspension to best suit tow vehicle specifications ( conditions apply)	POA

Outdoor Living (Note: all canvas is Jet Grey)	RRP (inc GST)
Rear insect screen upgrade to canvas	\$699
Tropical roof (in lieu of catch net)	\$990
Zip on family room tent with solid vinyl floor	\$1,699
Triangular sail awning	\$399
Quick Cover™ shade wall kit (2 x walls)	\$799
Annex – roof, kitchen end and fridge wall	\$2,170
Annex – 2 <sup>nd</sup> end wall with or without window	\$599
Annex – long (side) wall with 2 x windows and door	\$1,499
Draught skirt	\$479
Additional plumbed gas line with quick snap connector (for use with “flame failure” gas device)	\$255

Power	RRP (inc GST)
Redarc 160W monocrystalline solar blanket (rear hatch mounted)	\$850

Storage	RRP (inc GST)
Additional adjustable shelf in RHS front boot	\$250
Anderson plug in RHS front boot locker	\$65
Drawbar extension	\$750
ISI 2 bike rack inc chassis mount (requires drawbar extension)	\$1,475
Optional ISI car fit kit (vehicle info required for specific pricing)	POA

Trim Colour Options (Orange is standard)	RRP (inc GST)
Trim colour options	POA



The **MK6 generation** builds on the rock-solid reputation Tvan's have established over 26 years. They are known for their bulletproof build and go-anywhere off-roadability since they first hit the market.

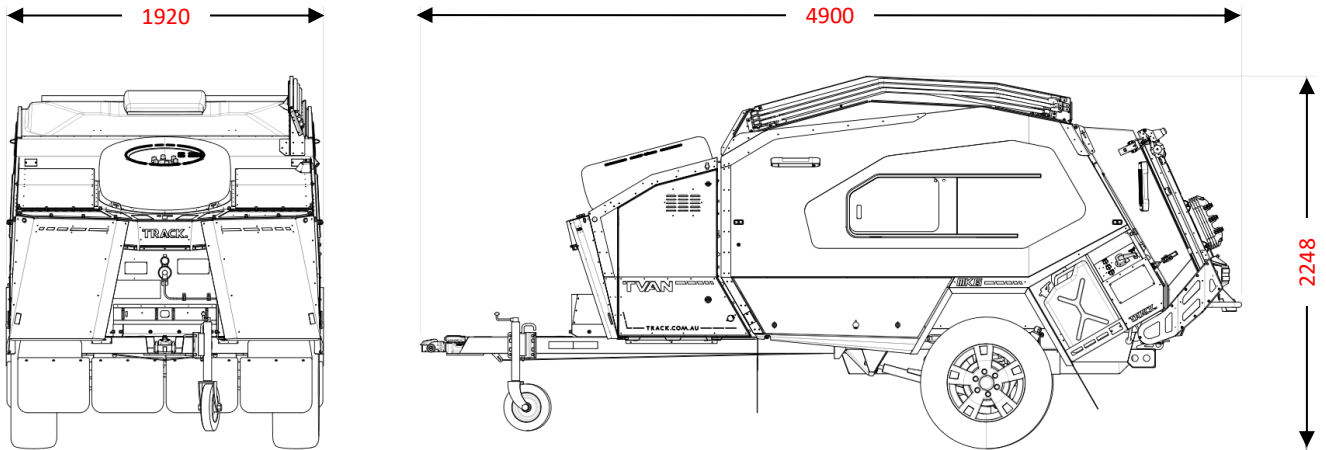

For the first time since the Tvan's introduction, the side body profile undergoes a substantial redesign in the MK6. This change allows for **greater headroom, improved practicality, and a more spacious feel**, particularly toward the front of the van.

The shape of the side windows, one of the Tvan's most distinctive visual features, has also changed to suit the new body shape. Noticeably **20% larger glass opening windows** will let **significantly more light** into the interior, enhancing the feeling of spaciousness. **Improved interior lighting** will further contribute to a **brighter and more modern feel**.

The Quick Cover™ awning has been redesigned to offer significantly **more coverage and increased headroom**, particularly at the front of the van.

The new front boot for the Tvan MK6 receives a substantial refresh with **new options and features** including:

- a **40% larger fridge compartment** and
- a **20% larger pantry**.

The rear deck receives **aesthetic and structural improvements**.



TRACK is proudly represented by your local dealer:



[www.tracktrailer.com.au](http://www.tracktrailer.com.au)  
sales@tracktrailer.com.au  
Tel: 03 8727 6100



RVMAP™

**MC2** ASYMMETRIC LINK SUSPENSION



**TRACK.**  
"RVs THAT INSPIRE"